

CNC Lathe

■ Designed for Rigidity

ML300

**Linear Guideways
Rapid Feedrate, Rapid Turret Index
For Ultra High Productivity**

Machines are made of Meehanite cast iron, the stress-relieved structure features metallic stability and deformation-free characteristics for long term static as well as dynamic accuracy.



Manford ML Lathe employs Japan-made high performance linear motion guideways on both X and Z axis, aiming to satisfy customers who demand high productivities. The A2-6 spindle is capable of accommodating 52 mm bar material that is the most common needed by job shops.



30°

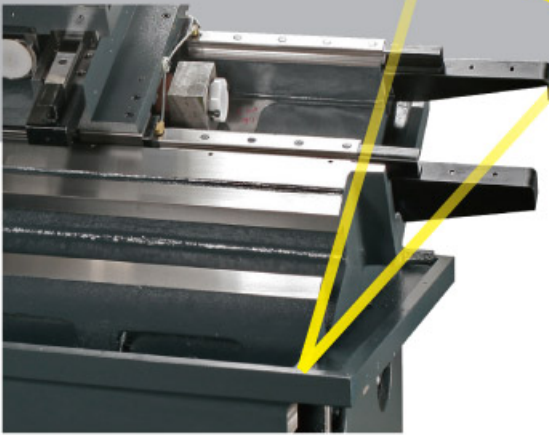

The one-piece slant bed design absorbs the cutting force more effectively. Compared to the traditional flat bed design, the distance between slide ways and cutting point is shorter, the cutting force is conducted to the ground via the shortest path.



TSUBASHI ball screws

For the optimum axes feedrate of 30 M/Min. without compromising rigidity, the X and Z axis Manfred ML320 is fitted with Japan TSUBASHI ball screws, featuring high sensitivity in motion control, free from stick-and-slip problem, and high rigidity.

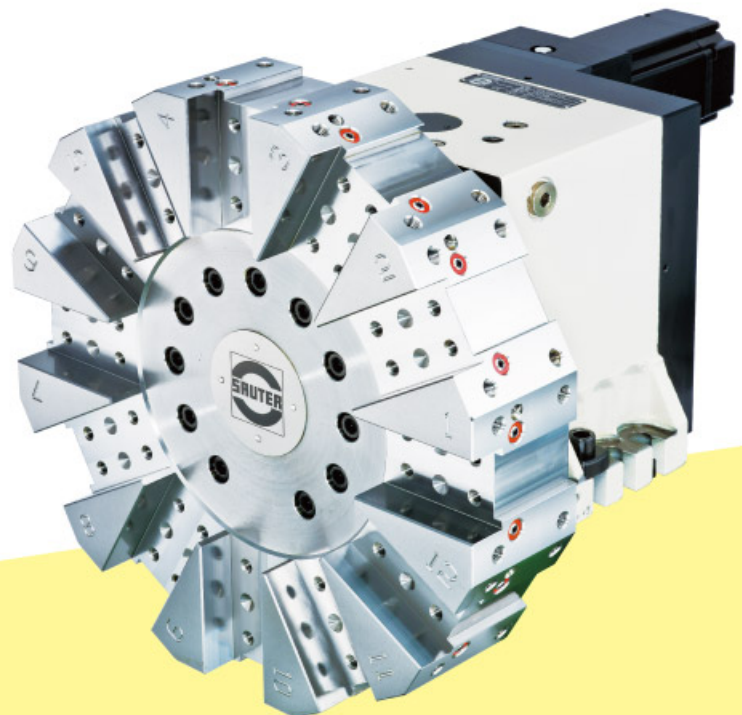
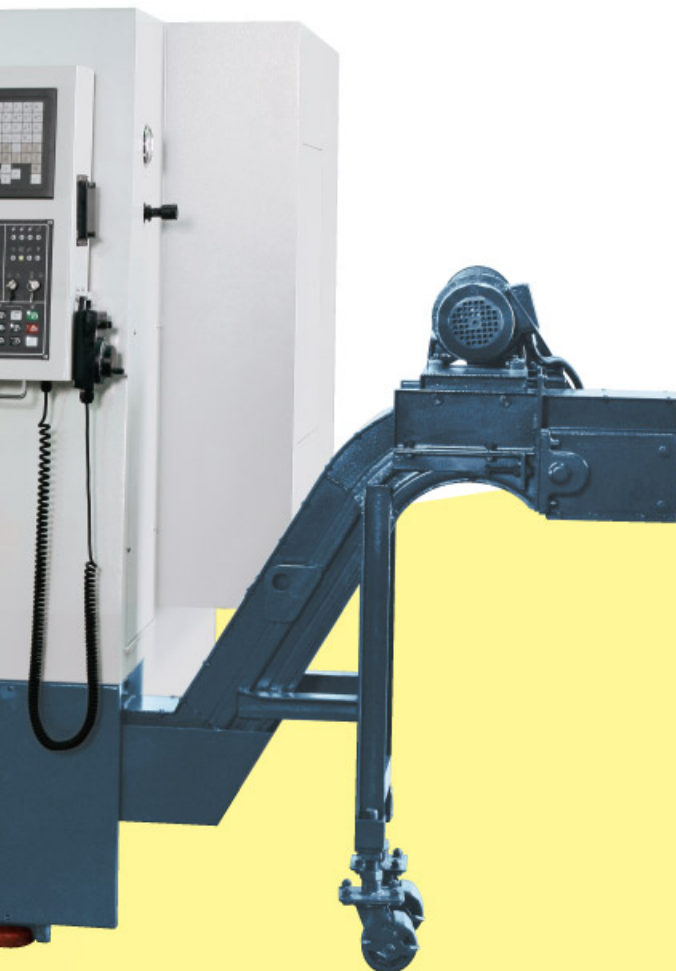

Position Turret

The high performance turret features smooth and fast tool index without error. High positioning accuracy and repeatability allow each lathe to achieve the highest cutting accuracy. Fast tool index can be accomplished in a second.

MH320 / 350

Box Guideways

High Rigidity, High Performance

X Axis = 230
Standard Z Axis = 550 mm.
Optional: 800 / 1050 mm.



Compact design of Manford

The Manford MH series is high performance CNC lathe with box guideways. Coated with Turcite B and grooved with lubrication oil channel, the box guideways' design allows the most rigid performance to deal with heaviest duty cutting.

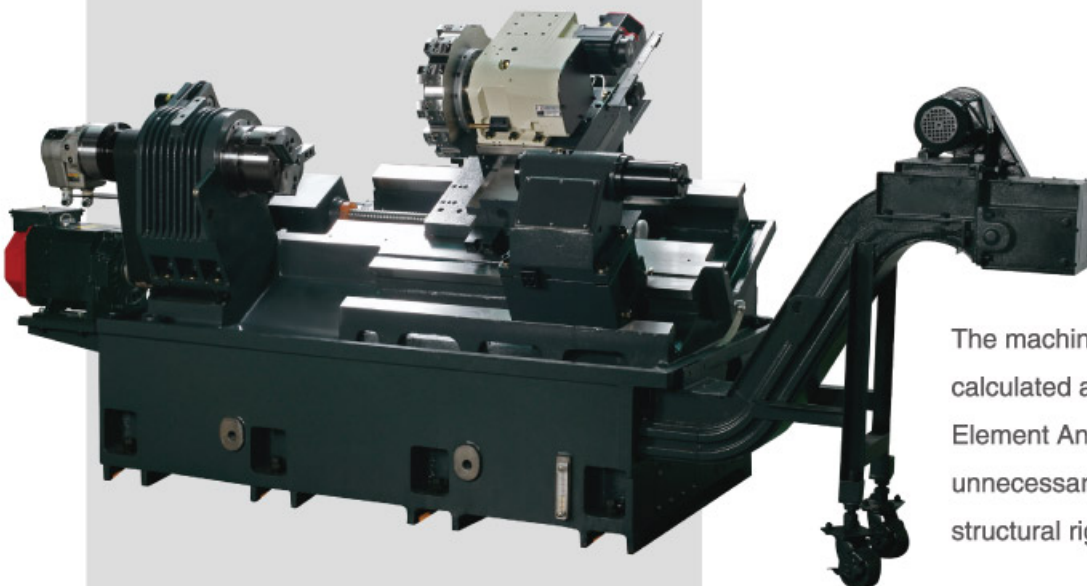

The machine base's inner ribs are calculated and deployed through Finite Element Analysis, which reduces unnecessary mass and boosts the structural rigidity to the optimum level.

Precision Hand Scraping

Every contacting surface is precision hand scraped to increase the flatness and improve geometric accuracy of the whole assembly.

Machines are made of Meehanite cast iron, the stress-relieved structure features metallic stability and deformation-free characteristics for long term static as well as dynamic accuracy.

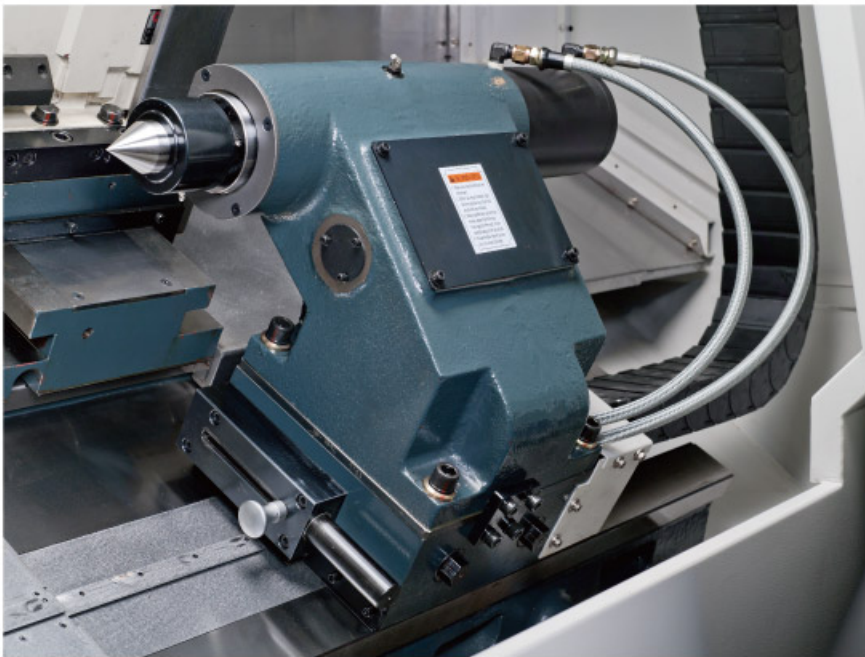

Hydraulic Unit

Tailstock

The hydraulic tailstock can be controlled by NC via an actuating pin; the quill thrust can be adjusted manually. Live center pin is optional.

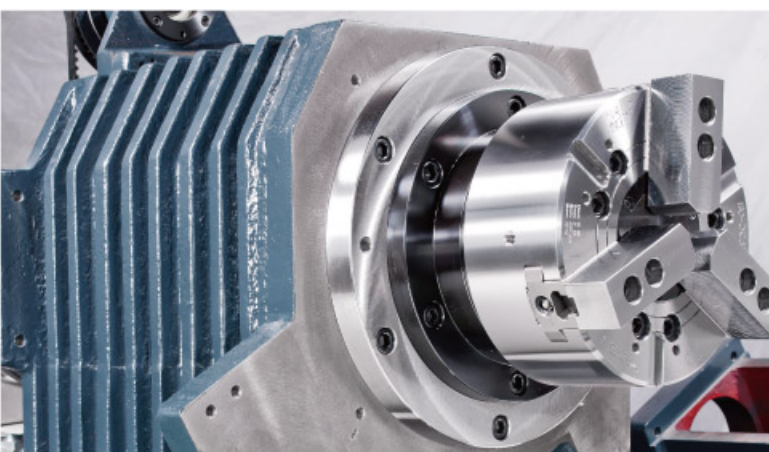

Sturdy Headstock with Spindle

The dynamic balanced spindle is powered by a 20 HP (MH320) and 25 HP (MH350) motor. The inner bore of headstock casting is fine-bored to embraces spindle cartridge firmly and precisely, plus the symmetric external ribs to minimize and stabilize the thermo expansion, the entire unit features low vibration, low noise and low temperature rising.

MH320C / 350C

Additional Axis = Additional Machine
High Rigidity, High Performance
Extraordinary Versatility

VDI 40 Live Tooling CNC Lathe



The combination of turning and milling function in one machine may boost productivity for more than double. Manford MH320C / MH350C is dedicated to customers who needs high quality high performance machine with appealing price level. By adopting state-of-the-art power turret system from Europe, the highest price-performance ratio machines from Manford are your best choice.

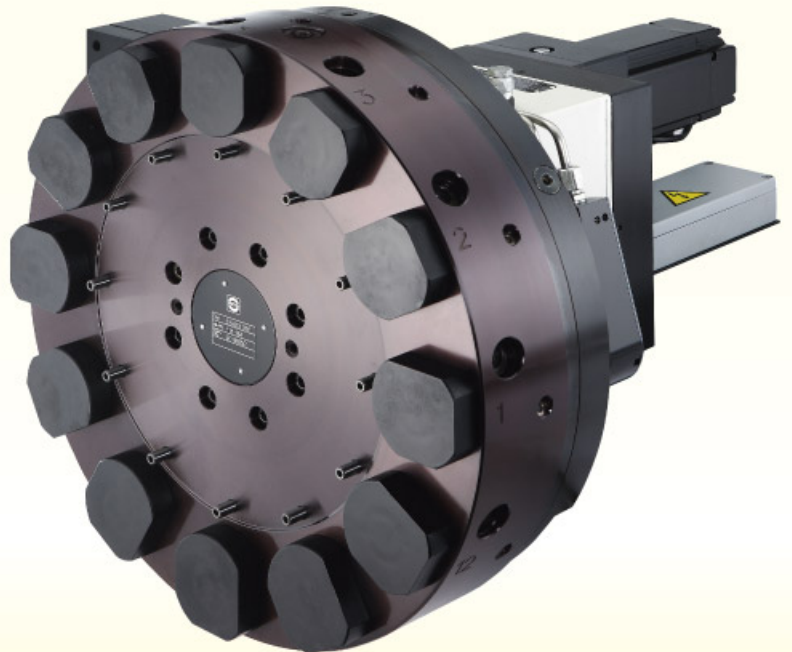
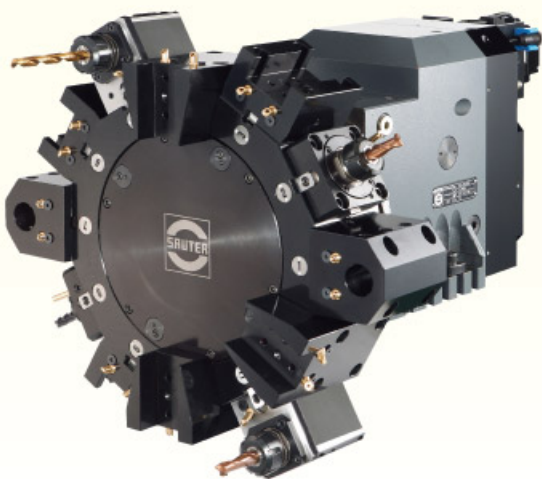



Servo Turret with Milling Function

The Italian

Diplomatic Live

Tooling Turret is selected on Manford MH320C and MH350C. The VDI 40 turret features superfast indexing time. High power of 5.5 kW drives the milling tools in axial and radius direction, delivering a low noise rotation and high quality cutting performance.

Axial Milling



Cs Axis with External Position Coder

With the external encoder and hydraulic braking system, the Cs Axis angle is accurately controlled and orientated, allowing rigid and precise operation in both turning and milling jobs.

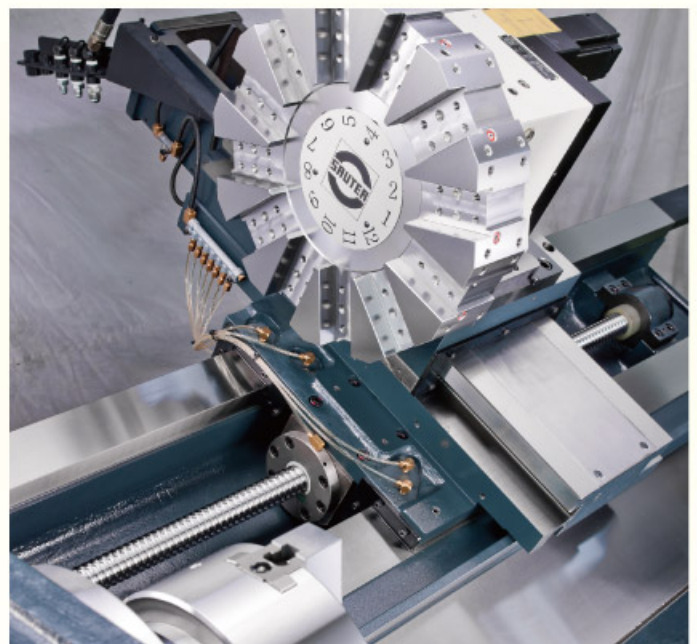

Direct Transmission

The C3 grade pretensioned ball screws are directly coupled with servo motor, featuring high servo response and superb positioning accuracy.

Optional



In addition to the standard turret, the Manford CNC Lathe is also available with VDI or BMT specification to meet customers' demand. (optional)



Workpiece Measurement

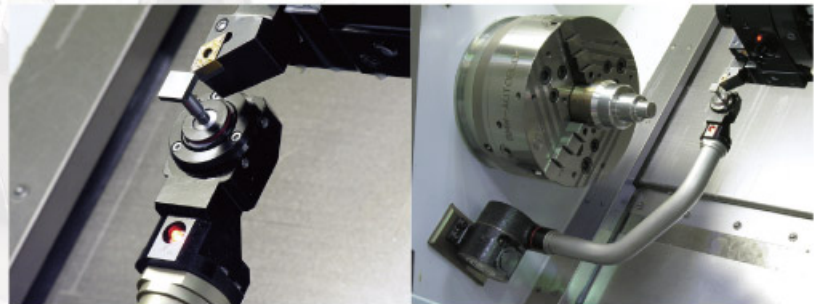

Tool Length Measurement

The function can be selected as manual or automatic driven. (optional)

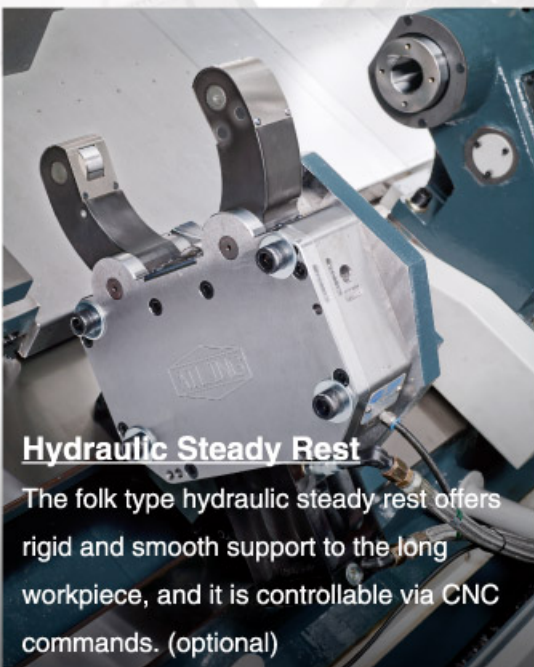

Hydraulic Steady Rest

The folk type hydraulic steady rest offers rigid and smooth support to the long workpiece, and it is controllable via CNC commands. (optional)

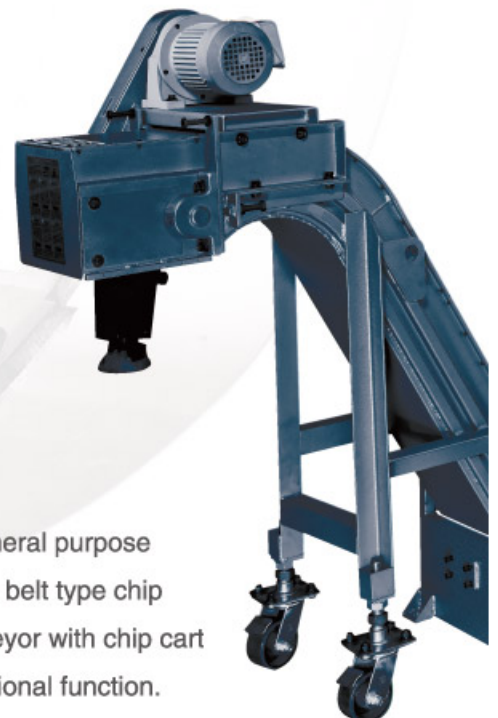

A general purpose hinge belt type chip conveyor with chip cart is optional function.

Interference Diagram

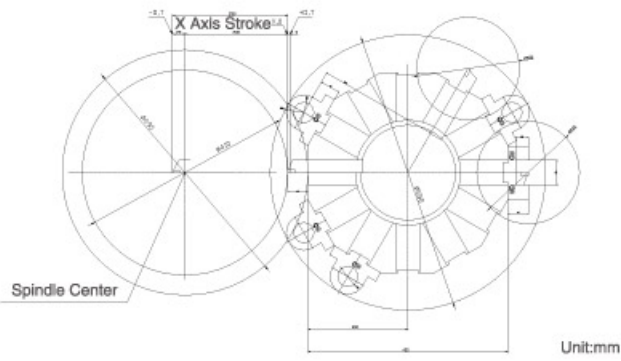

12T / 8" or 10" Chuck
Standard for MH320 / 350

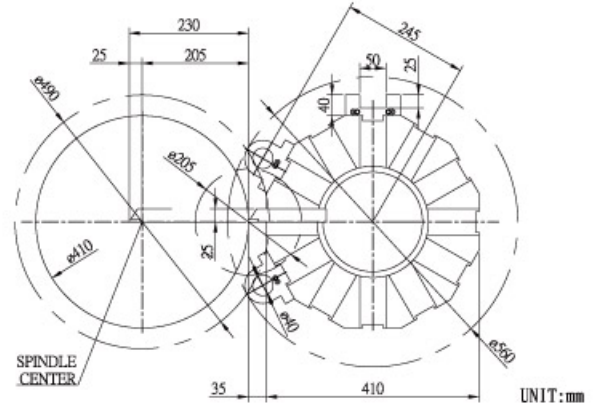

12T / 8" or 10" Chuck
Standard for MH320C / 350C

Tooling System

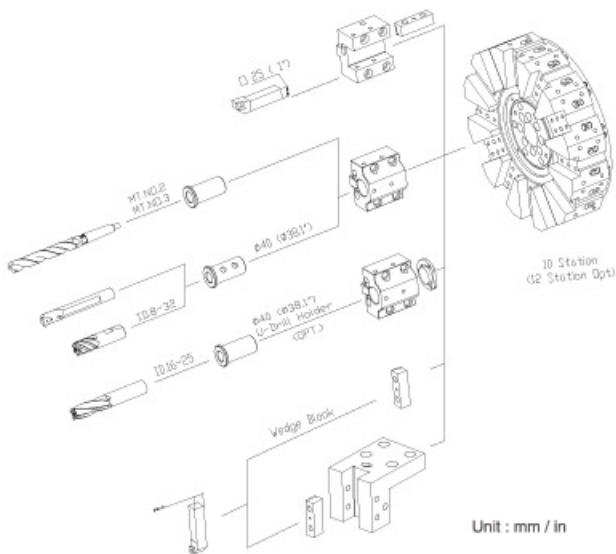

Standard for ML300, MH320 / 350

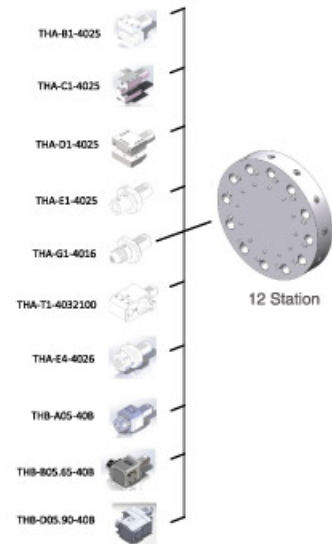

Standard for MH320C / 350C

Working Range

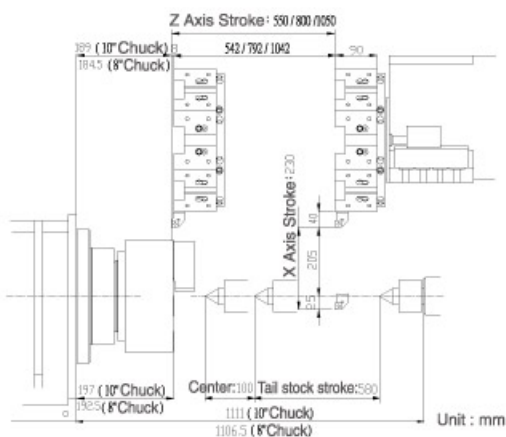

Standard for MH320 / MH350

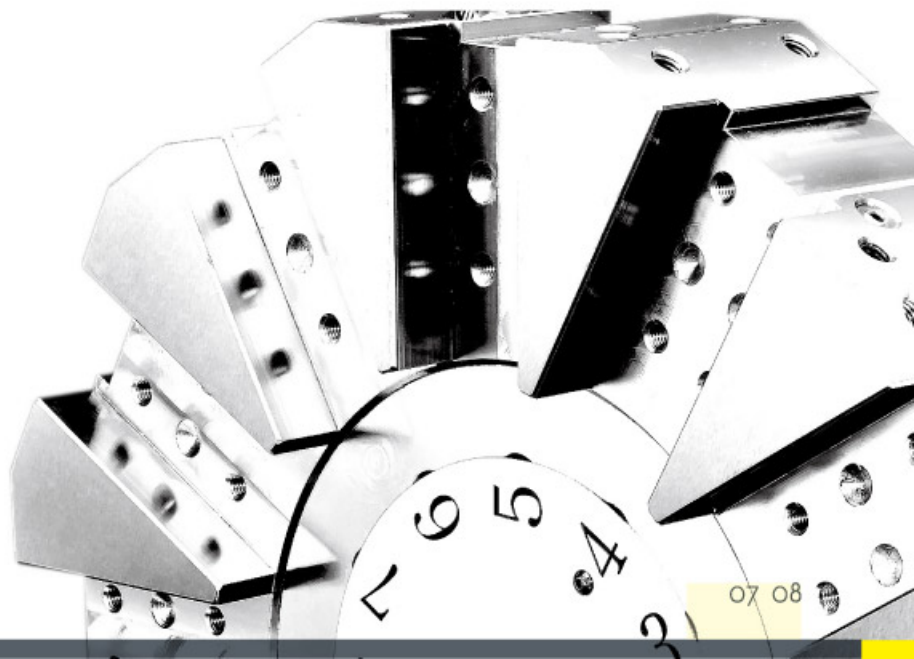

Power Chart

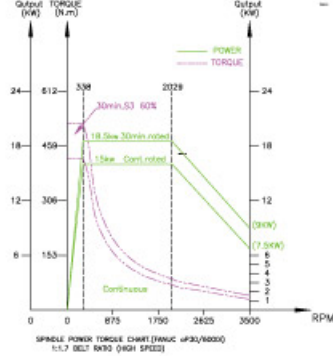
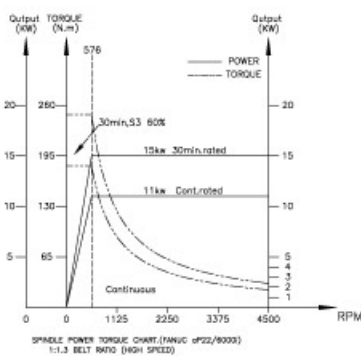
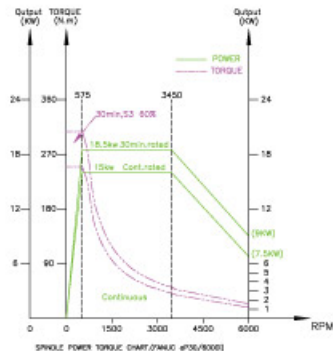
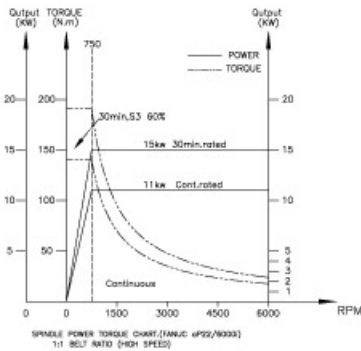

Standard for ML300, MH320, MH320C

Standard for MH350, MH350C

Standard accessories

- 8" (10") Hydraulic chuck (Taiwan made, incl, hard jaws and soft jaws 1 set each)
- Coolant system
- Removable coolant tank
- Leveling bolts and pads
- Lubrication system

- MT-5 live center x 1
- Work lamp
- Foot switch for hydraulic chuck
- Spare parts lists / Operation,
- Maintenance and Electrical Manual

Optional accessories

- Chip conveyor and chip cart
- Hydraulic tailstock system
- Programmable tailstock system
- Parts catcher
- Pneumatic automatic door
- Foot switch for tailstock
- Manual tool length measurement
- Automatic tool length measurement

- EMC CE Safety package
- Oil skimmer
- Transformer
- High pressure coolant pump
- Automatic bar feeder
- Anti-crash safety clutch
- Grease lubrication system
- 3-color pilot lamp

Power Chart

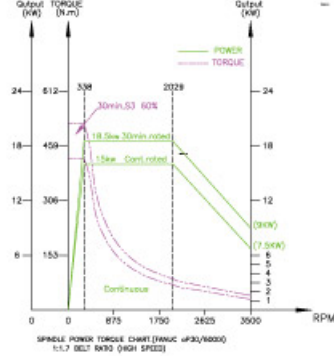
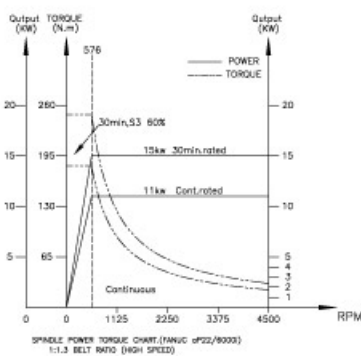
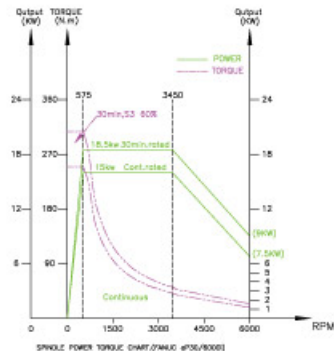
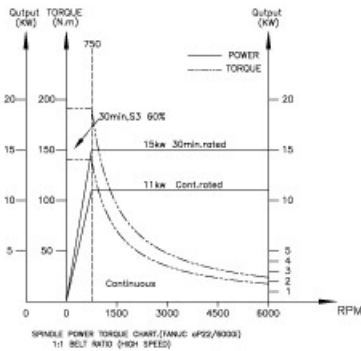

Standard for ML300, MH320, MH320C

Standard for MH350, MH350C

Standard accessories

- 8" (10") Hydraulic chuck (Taiwan made, incl, hard jaws and soft jaws 1 set each)
- Coolant system
- Removable coolant tank
- Leveling bolts and pads
- Lubrication system

- MT-5 live center x 1
- Work lamp
- Foot switch for hydraulic chuck
- Spare parts lists / Operation,
- Maintenance and Electrical Manual

Optional accessories

- Chip conveyor and chip cart
- Hydraulic tailstock system
- Programmable tailstock system
- Parts catcher
- Pneumatic automatic door
- Foot switch for tailstock
- Manual tool length measurement
- Automatic tool length measurement

- EMC CE Safety package
- Oil skimmer
- Transformer
- High pressure coolant pump
- Automatic bar feeder
- Anti-crash safety clutch
- Grease lubrication system
- 3-color pilot lamp



Manford Machinery Co., Ltd.

No. 18 Hsin Jen Rd. Sec. 1 Taiping city, Taichung , TAIWAN

Tel : 886-4-22754899

Fax : 886-4-22758737

<http://www.manford.com.tw/>

Email: manford@manford.com.tw